

# STEP 1

Carefully place the **Full Hutch** into position, taking care to not scratch the work surface. Allow for 1/2" set back from each work surface edge. Remove the metal panel covers from the inside, and after drilling 1/8" starter holes, drive (4) work surface screws through the Full Hutch and into the work surface.

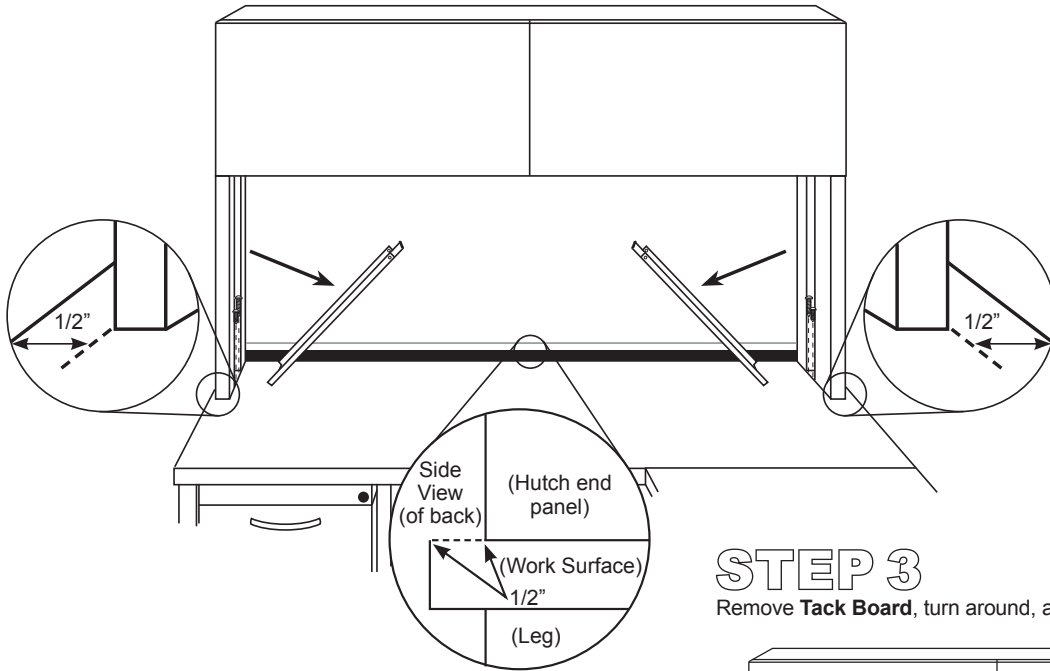

# STEP 2

Replace the **Metal Panel Covers**.

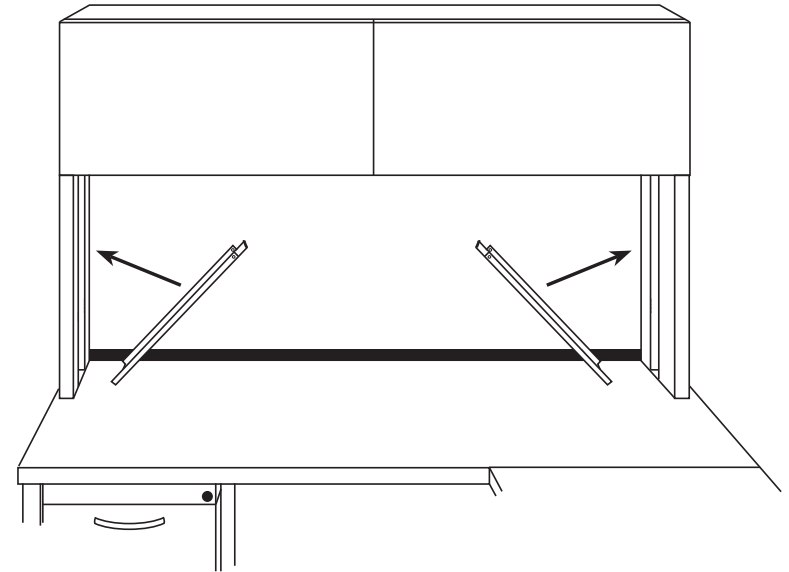

# STEP 3

Remove **Tack Board**, turn around, and re-install.

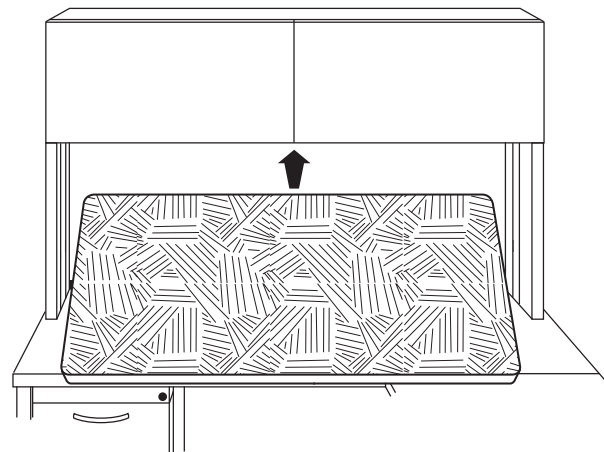

electric screw driver



#2 Phillips



work surface screw



1/8" drill bit